

# Vivi Hardware Specification

Model: VWP-100 (rev 1.2)

---

## Overview



## Model

VWP 100 Receiver LAN

---

## Key Features

- Durable anodised metal enclosure & steel chassis
- Mounting options for permanent installation
- Easy access reset switch

---

## Introduction

The VWP-100 is a durable and secure receiver device for connecting computers and mobile devices to a display screen. The device is pre-installed with operating software and is controlled by a cloud-based administration portal. Users access the device using a Client Application installed on their computer or mobile device.

---

## Features

### Device Features

#### Device Connectivity

- 1 HDMI
- 2 USB
- 1 RJ-45 LAN / 2.4ghz Wireless Configuration Access

#### Network

- Supports DHCP and Static IP ranges
- Supports SSL inspection / MITM
- Supports Proxies
- Supports NTP or TLS Time synchronisation

#### Wireless Device Configuration

- Connect directly to the device using a temporary wireless access point

#### Physical Features

- Kensington lock support
- Optional mounting plate

### Operating Requirements

The VWP-100 is the hardware component of the Vivi Product Suite. The device can only be used in conjunction with official Vivi Software and requires an active account to function.

The device must be configured on the network prior to use. Device configuration can be achieved through a browser-based console which can be accessed either natively through the inbuilt wireless access point or via the devices IP.

Full instructions for device configuration and management are available on the Vivi website:

<http://vivi.io/support>



---

## Technical Specification

### Hardware Configuration

SoM Model	NXP Freescale IMX6 based
Processor	iMX6 Quad Core ARM Cortex A9
Memory	2GB DDR3
Storage	8GB eMMC
OS	Linux (Pre-installed)
Connectors	1 RJ-45 LAN 2 USB 2.0 1 HDMI
Power Connector	2.1 x 5.5 mm Fixed Tip Positive (Twist Lock)
Power Requirements	12V DC @ 2A
Dimensions - Device	124 x 80 x 28.3 mm
Dimensions - Mounting Plate	145 x 80 x 1 mm
Dimensions - Packaged	155 x 108 x 52 mm (excluding PSU)
Weight	Device only: 285g Device and PSU: 585g
External Controllers	Reset Button
Enclosure	Anodised Metal
<b>Physical Security</b>	Kensington lock compatibility
<b>Included Accessories</b>	12V 2A Power Supply Unit Mounting Plate with Screw Kit Self-adhesive rubber feet
<b>Operating Environment</b>	Operating Temperature 0°C to 40°C Relative Humidity 5% to 90%
<b>PoE</b>	Requires a 12VDC PoE Splitter Adaptor (not included) The device <b>does not</b> support native PoE

---

## Configurations

VIVI Wireless Presenter	1 Device + PSU, 1 Standard License*
VIVI Starter Pack	4 Devices + PSUs 4 Introductory Licenses
VIVI Warranty 3Y	3 Year Product Replacement
VIVI Warranty 5Y	5 Year Product Replacement

\* Tiered licensing is available for multi device installation



# Hardware Schematics

## 1. Enclosure

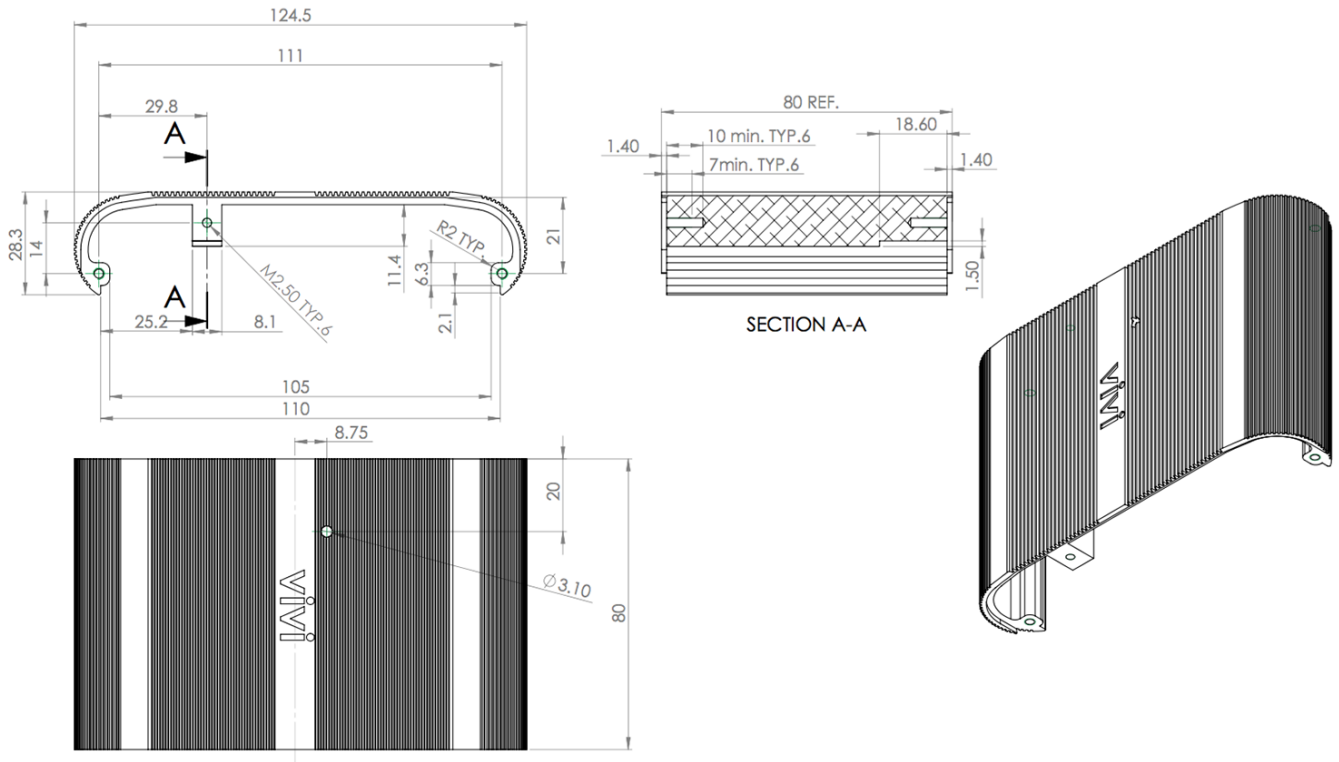

## 1. Chassis - Flat

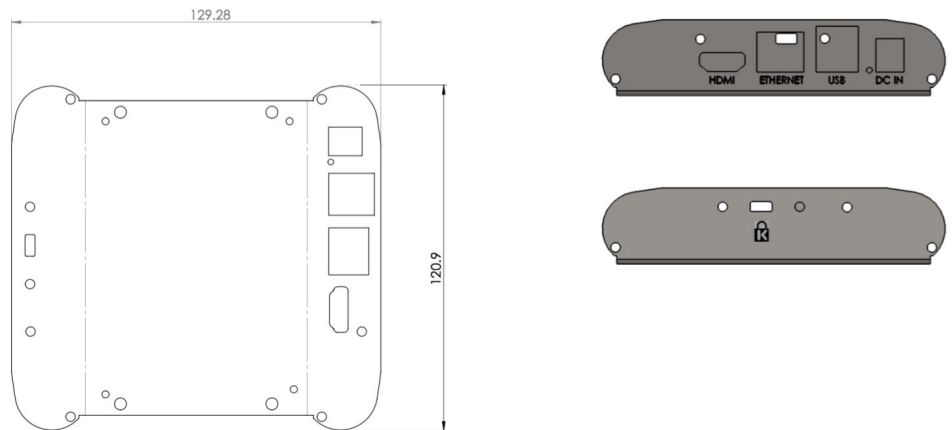

### 3. Chassis - Orthographic

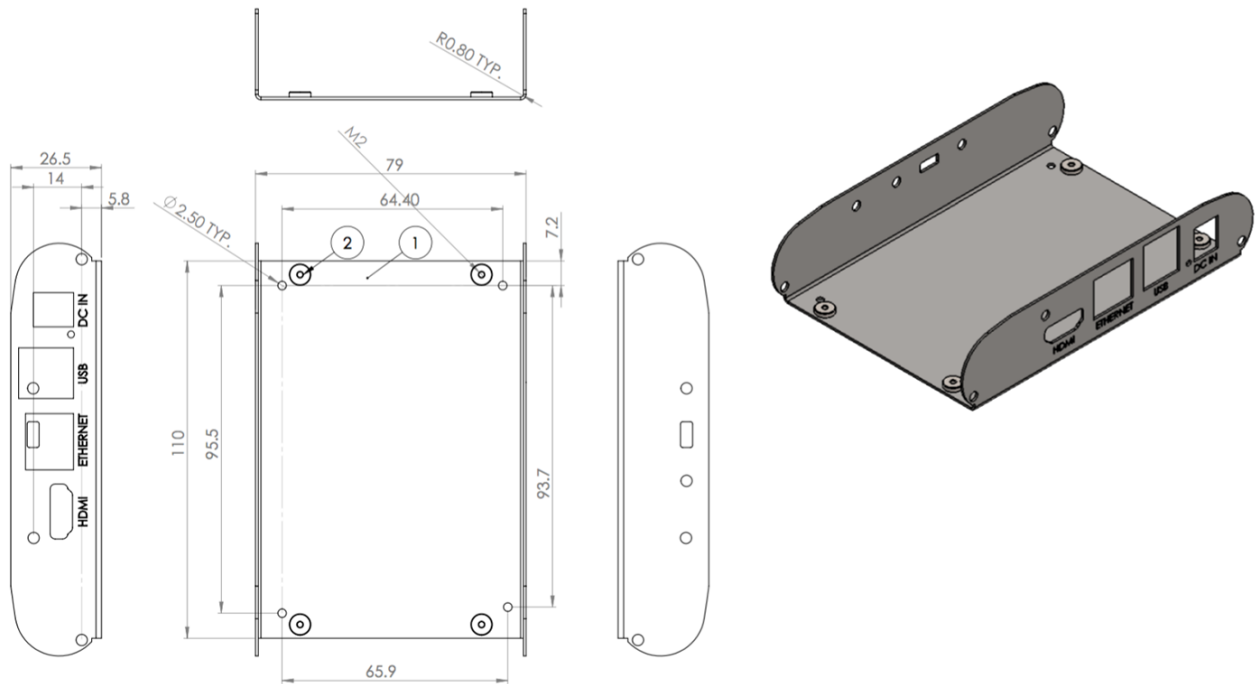

### 4. Mounting Plate

